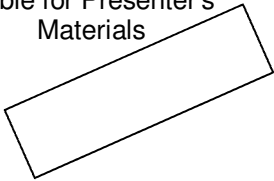

Table Groups Room Arrangement 12-24 Participants

Table for Presenter's
Materials



Screen



Flip Chart

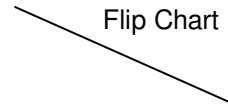

Projector & Cart for
Laptop

(If necessary—please ask whether
or not we plan to use PowerPoint
&/or play a DVD.)

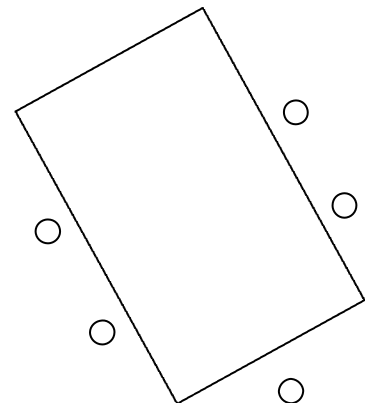
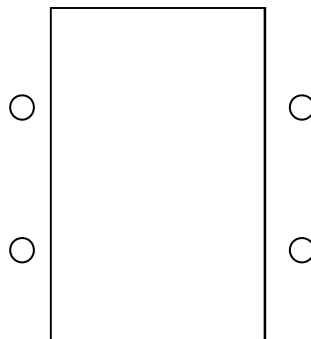
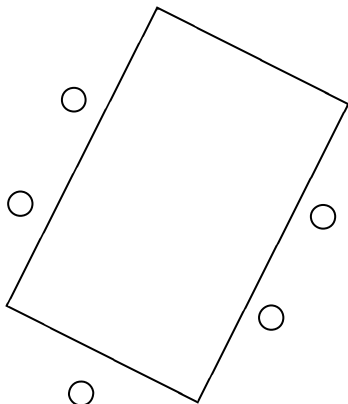
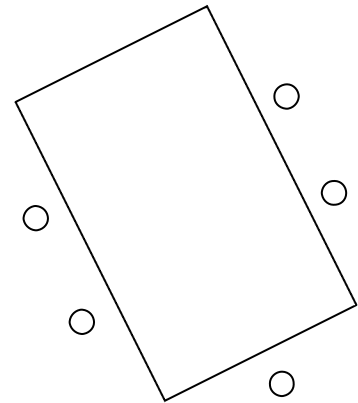
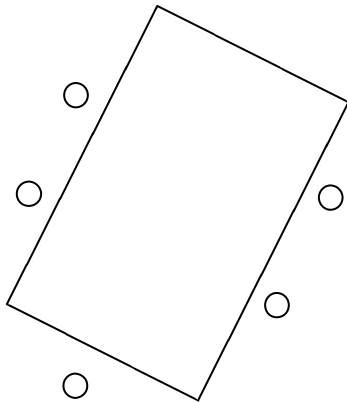

**A table group configuration is most ideal. Either round or rectangle tables would be great. If there isn't room for 5 tables, doing 3 tables with up to 8 people/table will work. Thanks for helping make your event a success!